

RoHS Compliant

Mechanical:

REV	MODIFICATION	DATE	DRAW	APPROVE

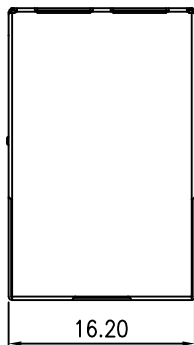

1. Material:

- 1 Housing: PBT UL94V-0 Black.
Insert: PBT UL94V-0 Black.
- 2 Shell: 30u" Ni Over Brass(C2680), T=0.20mm.
- 3 RJ45 Terminal: Phosphor Bronze(C5191) T=0.35mm
Plating: 6u" Gold Plated On Contact Area,
80u" ~120u" Tin Plated On Solder Area,
50u" ~80u" Ni Underplated Overall.
- 4 Tail Terminal: Brass(C2680) T=0.35mm,
Plating: 80u" ~120u" Tin Plated Over,
30u" ~50u" Ni Underplated Overall.

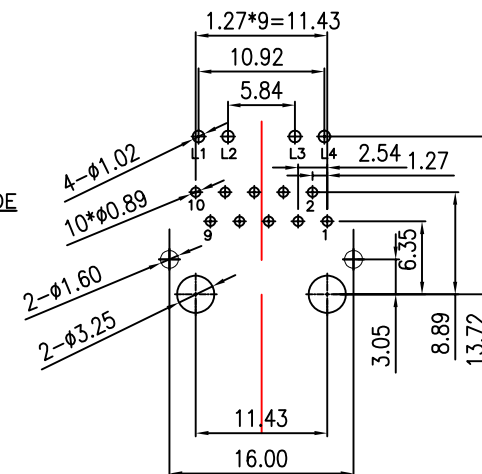
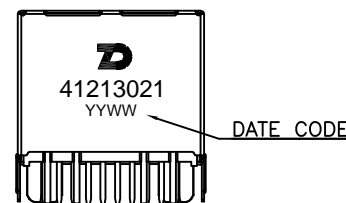
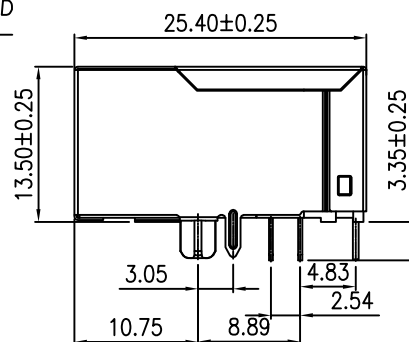
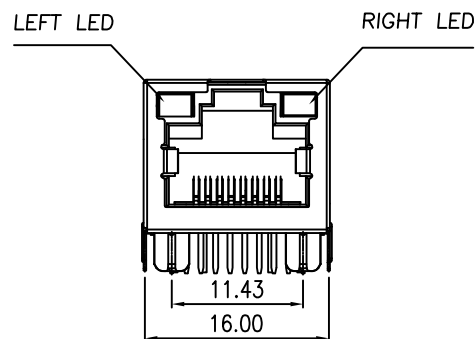

Recommended PCB Layout
(Tolerance: ±0.05)

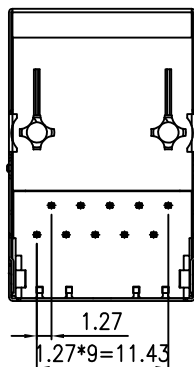

QC : Inspection Item	DIMENSION IN mm [Inch]		ZhenDeng Electronics Co.,Ltd		
	TOLERANCE UNLESS OTHERWISE SPECIFIED		TITLE		
	.X± 0.38	X.*± 2.0'	RJ45 1X1 TAB-UP 10/100/1000		
	.XX± 0.20	.X*± 1.0'	DRAWING NUMBER		
	.XXX± 0.10		41213021		
APPROVE	CHECK	DRAW	PROJ.	SHEET 1 OF 3	
		CLT 2024,05,10	SCALE 1:1	REV A	

RoHS Compliant

Schematic:

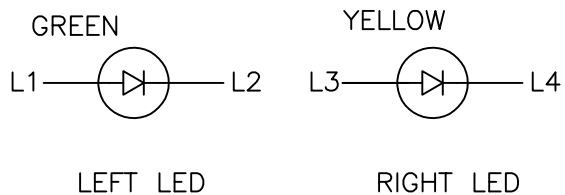
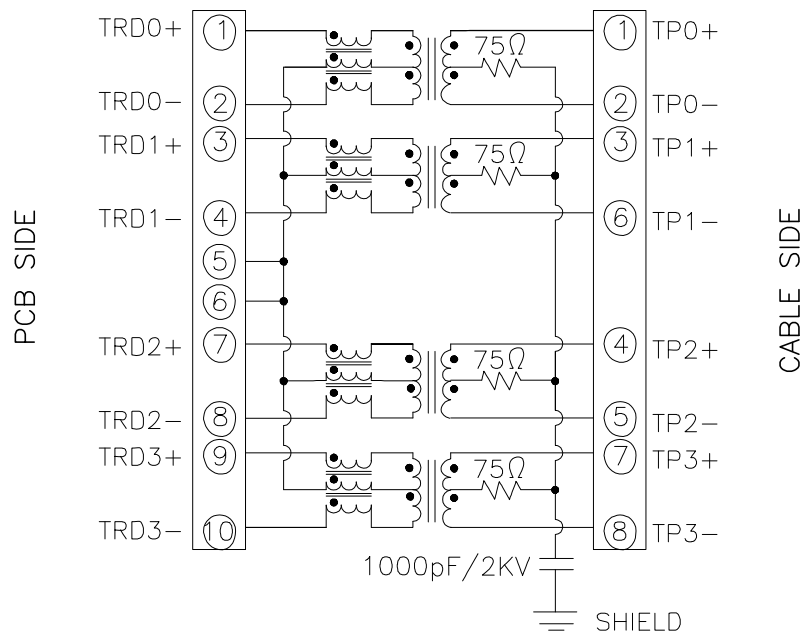

REV	MODIFICATION	DATE	DRAW	APPROVE

Electrical Specifications @25°C								
Turns Ratio (±2%)		OCL (uH Min.) @100 KHz/0.1V with 8mA DC Bias	Cross talk (dB Min.)				Hi-POT 1.0 mA (V)	
TX	RX		0.5-10 MHz	30 MHz	50 MHz	100 MHz	WITHOUT RESISTOR	WITH RESISTOR
1CT:1CT	1CT:1CT	350	-50	-40	-35	-30	1500 AC	2250 DC

Continue							
Insertion Loss (dB Max.)		Return Loss (dB Min.) @ Load 100 OHM					CMR (dB Min.)
1-100 MHz	100-125 MHz (10/100/1000)	1-30 MHz	30-50 MHz	60 MHz	60-80 MHz	80-100 MHz (10/100/1000)	1-100 MHz
-1.0	-1.2	-18	-16	-14	-12	-10	-30

Operating and Storage Temperature:
 Operating Temperature : -40°C to +85°C.
 Storage Temperature : -40°C to +85°C.

QC : Inspection Item	DIMENSION IN mm [Inch]		ZhenDeng Electronics Co.,Ltd		
	TOLERANCE UNLESS OTHERWISE SPECIFIED		TITLE		
	.X± 0.38	X.*± 2.0'	RJ45 1X1 TAB-UP 10/100/1000		
	.XX± 0.20	.X*± 1.0'	DRAWING NUMBER		
.XXX± 0.10		41213021			
APPROVE	CHECK	DRAW	PROJ.	SHEET 2 OF 3	
		CLT 2024,05,10	SCALE 1:1	SIZE A3	REV A

RoHS Compliant

REV	MODIFICATION	DATE	DRAW	APPROVE

Packing:

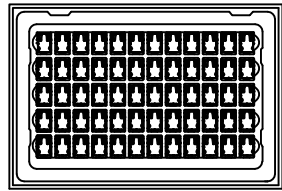

TRAY

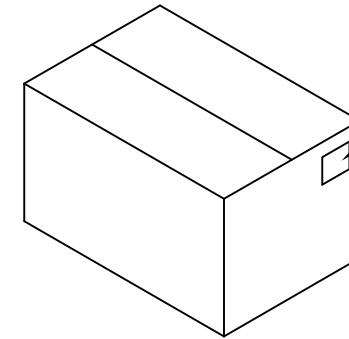

LABEL

DESICCANT

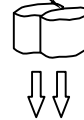

WATER-PROOF BAG

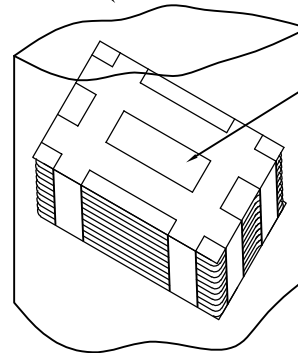

PE FILM

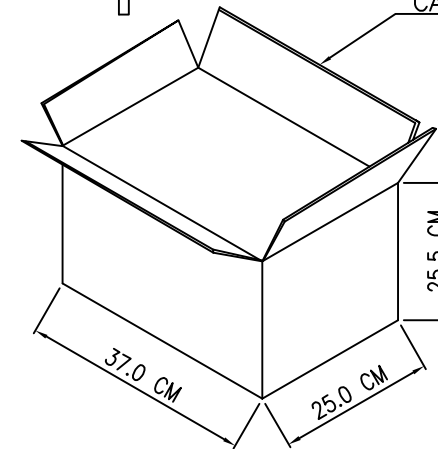

CARTON

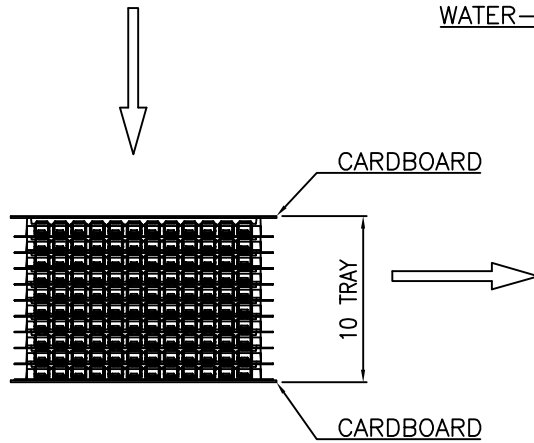

QC : inspection Item	DIMENSION IN mm [Inch]		ZhenDeng Electronics Co.,Ltd	
	TOLERANCE UNLESS OTHERWISE SPECIFIED		TITLE	
	.X± 0.38	X.*± 2.0'	RJ45 1X1 41- PACKING	
	.XX± 0.20	.X*± 1.0'	DRAWING NUMBER	
	.XXX± 0.10		41- PACKING	
APPROVE	CHECK	DRAW	PROJ.	SHEET 3 OF 3
		CLT 2024,05,10	SCALE 1:1	REV A

1 2 3 4 5 6 7 8