

RoHS Compliant

Mechanical:

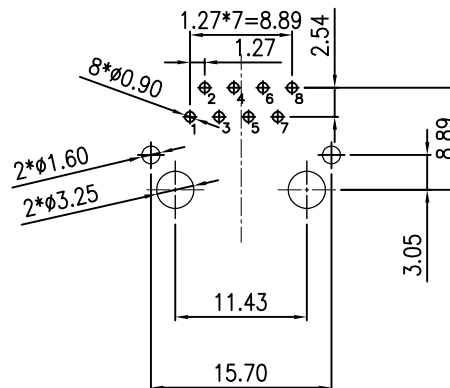
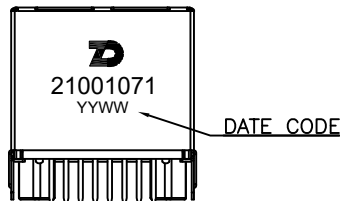
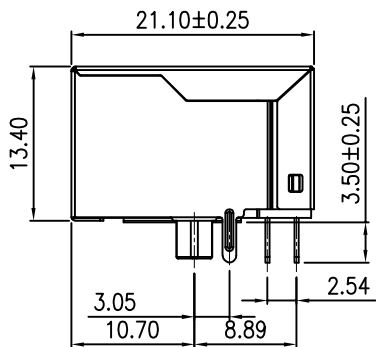
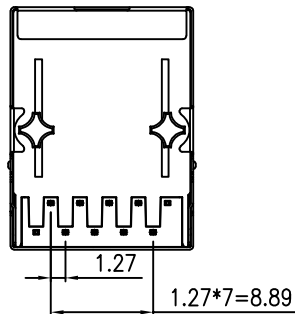
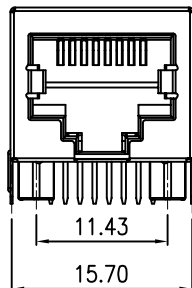
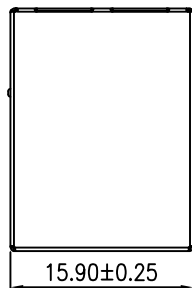

ConnectMaterial:

- 1.SHELL:COPPER ALLOY PLATING:30u”NICKEL MIN.
- 2.HOUSING AND INSERTER:PBT,UL94V-0,COLOR:BLACK.
- 3.RJ45 TERMINAL:PHOSPHOR BRONZE T=0.35mm
PLATING: 30u” NICKEL Min. UNDER PLATED
ALL OVER 100u” TIN Min. PLATED ALL OVER
6u”GOLD PLATED ON CONTACT AREA.
- 4.OHTERS TERMINAL:BRASS T=0.35mm
PLATING: 30u” NICKEL Min. UNDER PLATED
ALL OVER 100u” TIN Min. PLATED ALL OVER.

REV	MODIFICATION	DATE	DRAW	APPROVE

RECOMMENDED PCB LAYOUT
(COMPONENT SIDEVIEW)
ALL DIMENSION TOLERANCE ARE ±0.05mm

QC Inspection Item	DIMENSION IN mm [Inch]		ZhenDeng Electronics Co.,Ltd		
	TOLERANCE UNLESS OTHERWISE SPECIFIED		TITLE		
	.X± 0.38	X.*± 2.0*	RJ45 1X1 10/100 BASE-T		
	.XX± 0.20	.X*± 1.0*	DRAWING NUMBER		
.XXX± 0.10		21001071			
APPROVE	CHECK	DRAW	PROJ.	SHEET 1 OF 3	
		CLT 2024,05,10	SCALE 1:1	SIZE A3	REV A

RoHS Compliant

Schematic:

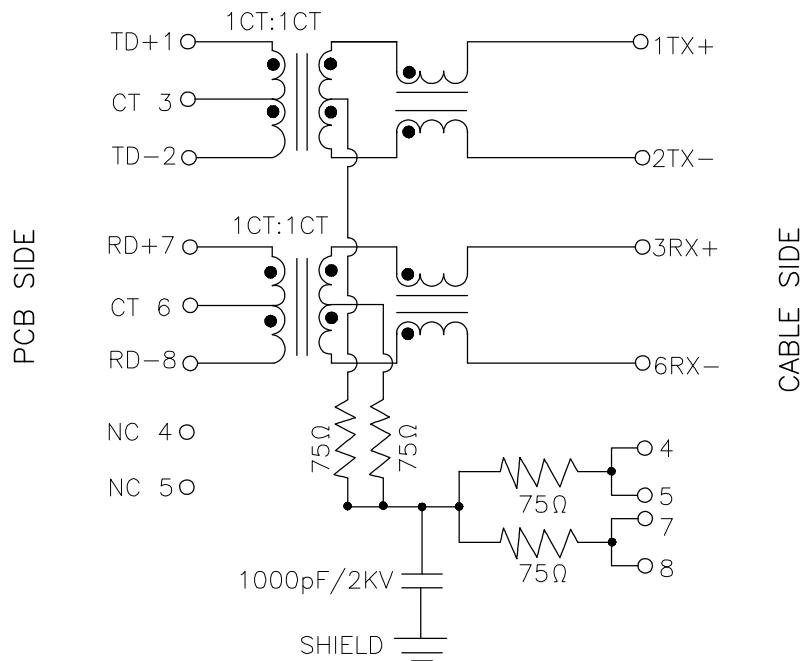

REV	MODIFICATION	DATE	DRAW	APPROVE

Electrical Specifications @25°C								
Turns Ratio (±2%)		OCL (uH Min.) @100 KHz/0.1V with 8mA DC Bias	Cross talk (dB Min.)				Hi-POT 1.0 mA (V)	
TX	RX		0.5-10 MHz	30 MHz	50 MHz	100 MHz	WITHOUT RESISTOR	WITH RESISTOR
1CT:1CT	1CT:1CT	350	-50	-40	-35	-30	1500 AC	2250 DC

Continue							
Insertion Loss (dB Max.)		Return Loss (dB Min.) @ Load 100 OHM					CMR (dB Min.)
1-100 MHz	100-125 MHz (10/100/1000)	1-30 MHz	30-50 MHz	60 MHz	60-80 MHz	80-100 MHz (10/100/1000)	1-100 MHz
-1.0	-1.2	-18	-16	-14	-12	-10	-30

Operating and Storage Temperature:
 Operating Temperature : 0°C to +70°C.
 Storage Temperature : -40°C to +85°C.

◎ : Inspection Item	DIMENSION IN mm [Inch]		ZhenDeng Electronics Co.,Ltd		
	TOLERANCE UNLESS OTHERWISE SPECIFIED		TITLE		
	.X± 0.38	X.*± 2.0°	RJ45 1X1 10/100 BASE-T		
	.XX± 0.20	.X*± 1.0°	DRAWING NUMBER		
.XXX± 0.10		21001071			
APPROVE	CHECK	DRAW	CLT	PROJ.	SHEET 2 OF 3
		2024,05,10	2024,05,10	SCALE 1:1	REV A

RoHS Compliant

Packing:

REV	MODIFICATION	DATE	DRAW	APPROVE

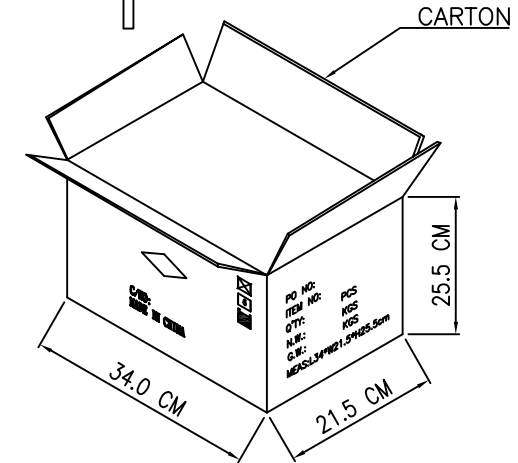
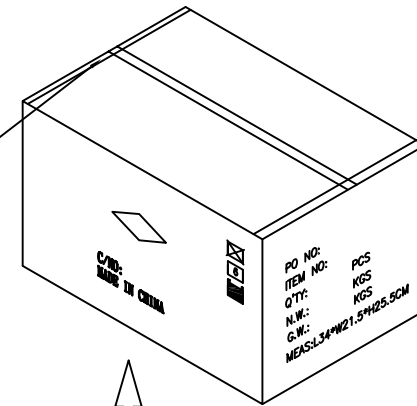
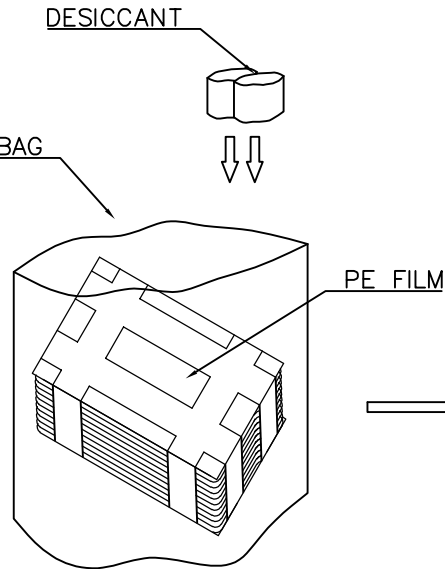
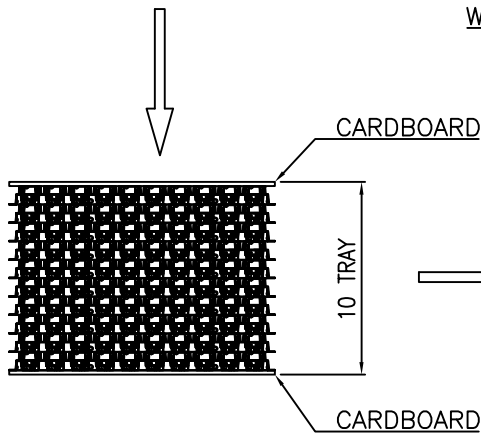
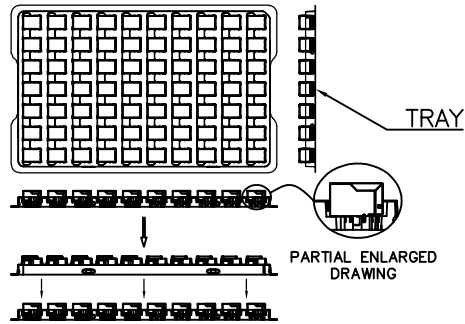

NOTES:

1. PRIMARY PACKING: 70PCS/TRAY
2. SECONDARY PACKING: 10TRAY/CARTON(700PCS/CARTON)
3. CARTON SIZE: 340x215x255mm

QC Inspection Item	DIMENSION IN mm [Inch]		ZhenDeng Electronics Co.,Ltd		
	TOLERANCE UNLESS OTHERWISE SPECIFIED				
	.X± 0.38	X.*± 2.0°	RJ45 1X1 21&31- PACKING		
	.XX± 0.20	.X*± 1.0°	DRAWING NUMBER		
	.XXX± 0.10		21&31- PACKING		
APPROVE	CHECK	DRAW	CLT	PROJ.	SHEET 3 OF 3
		2024,05,10	2024,05,10	SCALE 1:1	REV A